



# SHELTER STRUCTURES AMERICA

## PRODUCT SPECIFICATIONS

### SHELTER JET TENT

#### TENT SPECIFICATIONS

Model	Jet6
Span Width	6m
Eave Height	4.00m
Ridge Height	5.95m
Bay Distance	5m
Roof Pitch	18°
Longest Component	6.30m
Maximum Length	Unlimited in 5-meter increments
Max. WindLoad	115mph

#### FRAMEWORK

Main Profiles	112*203*4mm (4 channel)
Material	Hard Pressed Extruded Structural Aluminum 6061/T6

#### COVER

Material	PVC Coated Polyester Fabric
Features	650 or 850 g/sqm, Premium Grade, High Gloss White or Translucent, Waterproof, UV Resistant
Flame Retardant	DIN 4102 B1, M2; USA NFPA701

#### CONNECTING COMPONENTS

Hot Dipped, Structural Grade Corrosive Resistant Galvanized Steel

### JET TENT DRAWING

#### Rendering



#### Gable Drawing

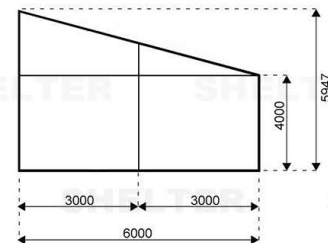

#### Frame Drawing

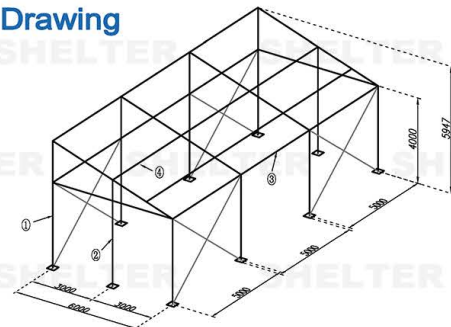

#### Profile Specifications

Upright Support Roof Beam ①	Gable Upright ②	Eave Purlin ③	Roof Purlin ④



**SHELTER STRUCTURES**  
**TENT MANUFACTURER**

**Shelter Structures America Inc.**

405 Via Chico Suite 1 Palos Verdes Estates, CA 90274

E: robert@shelterstructuresamerica.com C: (954) 559 8759

W: www.shelterstructuresamerica.com O: (424) 254 9172