



SHELTER STRUCTURES AMERICA

PRODUCT SPECIFICATIONS

SHELTER A-FRAME M-SERIES

TENT SPECIFICATIONS

Model	M10
Span Width	10m
Eave Height	4.00m
Ridge Height	5.70m
Bay Distance	5m
Roof Pitch	18°
Longest Component	5.60m
Maximum Length	Unlimited in 5-meter increments
Max. WindLoad	115mph

FRAMEWORK

Main Profiles	120*200*4mm (4 channel)
Material	Hard Pressed Extruded Structural Aluminum 6061/T6

COVER

Material	PVC Coated Polyester Fabric
Features	650 or 850 g/sqm, Premium Grade, High Gloss White or Translucent, Waterproof, UV Resistant
Flame Retardant	DIN 4102 B1, M2; USA NFPA701

CONNECTING COMPONENTS

Hot Dipped, Structural Grade Corrosive Resistant Galvanized Steel

M-SERIES DRAWING

Rendering



Gable Drawing

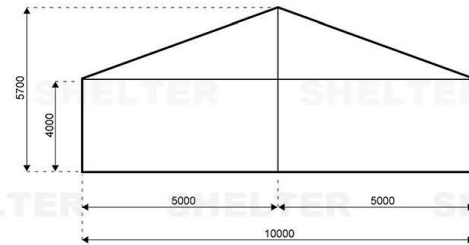

Frame Drawing

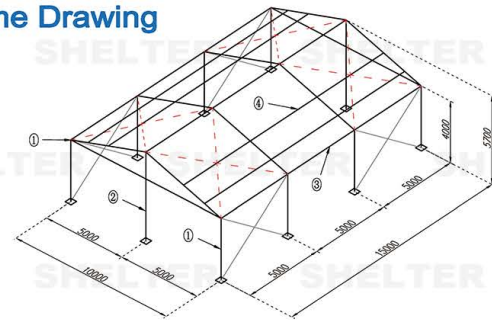

Profile Specifications

Upright Support Roof Beam ①	Gable Purlin ②	Eave Purlin ③	Roof Purlin ④



SHELTER STRUCTURES
TENT MANUFACTURER

Shelter Structures America Inc.

405 Via Chico Suite 1 Palos Verdes Estates, CA 90274

E: robert@shelterstructuresamerica.com

C: (954) 559 8759

W: www.shelterstructuresamerica.com

O: (424) 254 9172